DemoKit

USER MANUAL



Introduction

Welcome to the user manual for the DemoKit — a universal tool for demonstrating measurements of physical phenomena such as distance, mechanical stress, temperature, and vibrations.

This manual will guide you through the steps to properly assemble, use, and effectively apply the device in education, presentations, or field testing.



Access the video guide here

→ rvmagnetics.com/industries/industrial-demokit/manual

Contents

Introduction	2
Package contents	5
General rules	6
External coil	6
Starting the device	6
Connecting the device	7
Distance measurement	8
Stress measurement	9
Temperature measurement	10
Vibrations measurement	11
RAW measurement	12
Recommendations & FAQ's	13
About RVmagnetics	15

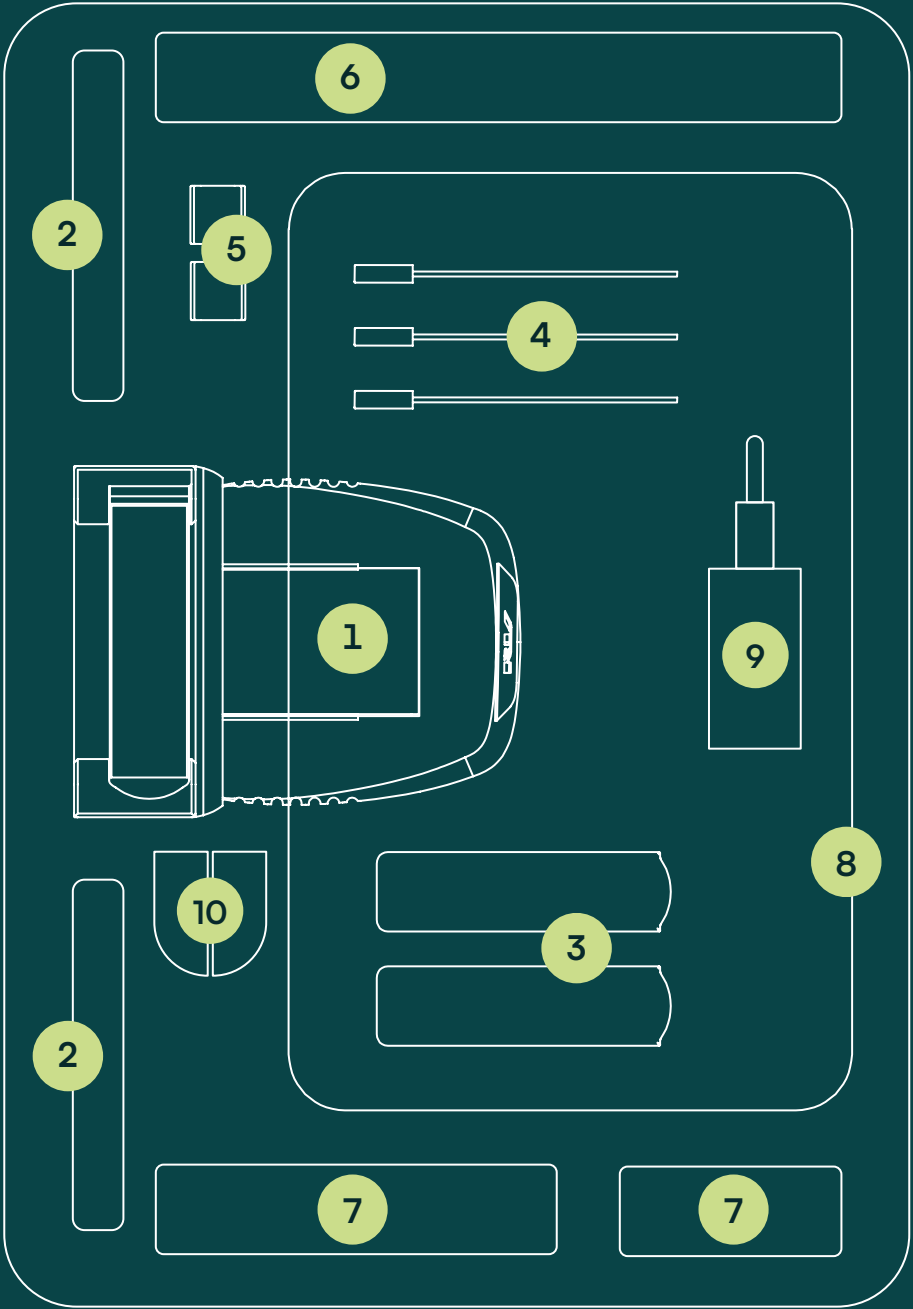

Package contents

- 1 Main DemoKit unit
- 2 Power bank (2 pcs)
- 3 Measurement strips **D** Distance, **S** Stress, **T** Temperature (6 pcs)
- 4 Carbon composite for vibration measurement (3 pcs)
- 5 Vibration weight (2 pcs)
- 6 Cable for external coil (if included)
- 7 USB Cable (2 pcs)
- 8 Tablet
- 9 Power adapter
- 10 Mounting guides (“ears”)

General rules

- **Mounting ears** 10 must be attached to the DemoKit unit before any strip can be used.
- Strips are labeled **D** (**D**istance), **S** (**S**tress), and **T** (**T**emperature).
- Each strip must be inserted label-up for correct measurements.
- The design only allows insertion in one direction to prevent errors.

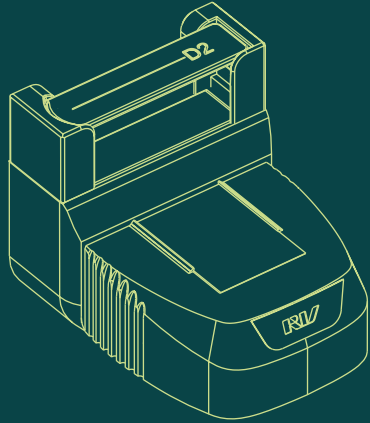

External coil

Some DemoKit versions support **external coil connection**:

- Insert the external connector 6 into the designated port.
- Flip the switch to change the internal/external coil option.
- Switch again to revert back.
- Connector fits only one way to avoid mistakes.

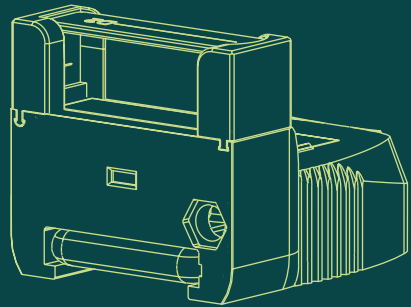

Starting the device

1. Insert the **power bank** so the LED lights remains visible.
2. **Turn on the device** using the switch on the underside. The indicator light confirms readiness.

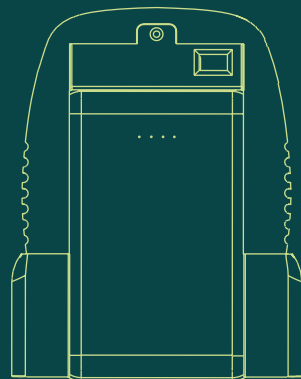

Connecting the device

After turning on the DemoKit device and tablet, **open the app** that corresponds to the measurement you want to perform.



Distance measurement

Using the **Distance bar**, it is possible to monitor changes in the height level between the sensing unit and the sensor itself.

The measurement is based on the MicroWire's sensitivity to the intensity of the sensing unit's magnetic field. The sensitivity can be fine-tuned down to tens of microns.

1. Step

- Insert the **D** labeled strip into the guide ("ears") securely.

2. Step

- The distance is monitored by tracking the positional changes of the MicroWire.

3. Step

- Results display on the accompanying software/ tablet.



Depending on the inserted strip choose BAR D1 or BAR D2 option for the correct measurement.

Stress measurement

Using the **Stress bar**, it is possible to detect mechanical stress and strain through bending of the material.

This approach enables monitoring of structural integrity, deformation, or load changes without causing damage to the material.

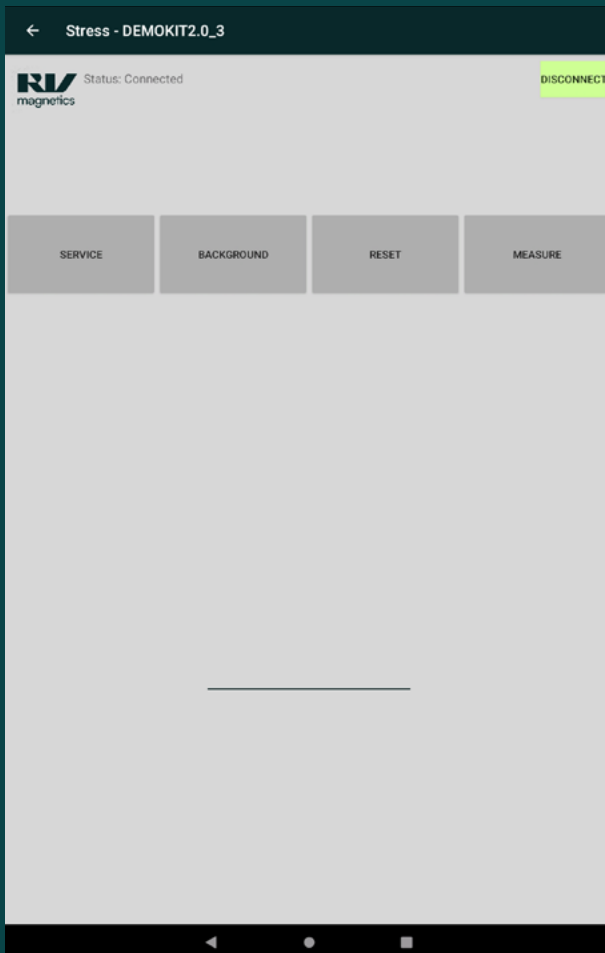

1. Step

- Insert the (S) labeled strip

2. Step

- After every change/ flip of the strip, press background for correct measurement. The system evaluates changes in the MicroWire's signal induced by mechanical deformation

3. Step

- Apply mechanical force (compression, elongation). If the strip is inserted with the (S) side facing upward, the applied stress corresponds to compression. If the (S) side faces downward, the applied stress corresponds to elongation.

The rise/fall of the column represents the intensity of the elongation/compression of the strip.

Temperature measurement

The **MicroWire sensor** attached to the surface of the strip enables contactless detection of temperature changes.

This approach can be applied effectively across a wide range of environments.

1. Step

- Place the **T** labeled strip in the mounting guides (“ears”). Touch the MicroWire with a non-magnetic object at a non-room temperature (e.g. finger, ice pack) to see the temperature change.

2. Step

- Depending on the inserted strip press either BAR T1 or BAR T2.

3. Step

- The MicroWire detects thermal changes, which reflect in the measurement results.

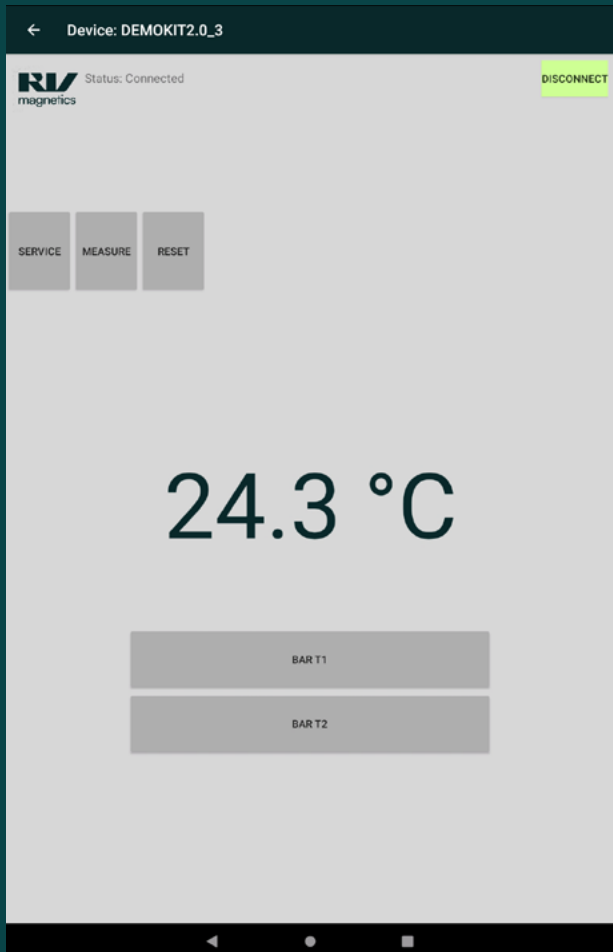

After the correct strip (T1/T2) is chosen, the room temperature should be displayed.

Vibrations measurement

The **MicroWire sensor** detects and analyzes vibrations across a wide frequency range.

This enables early identification of mechanical issues, wear or imbalance in moving parts.

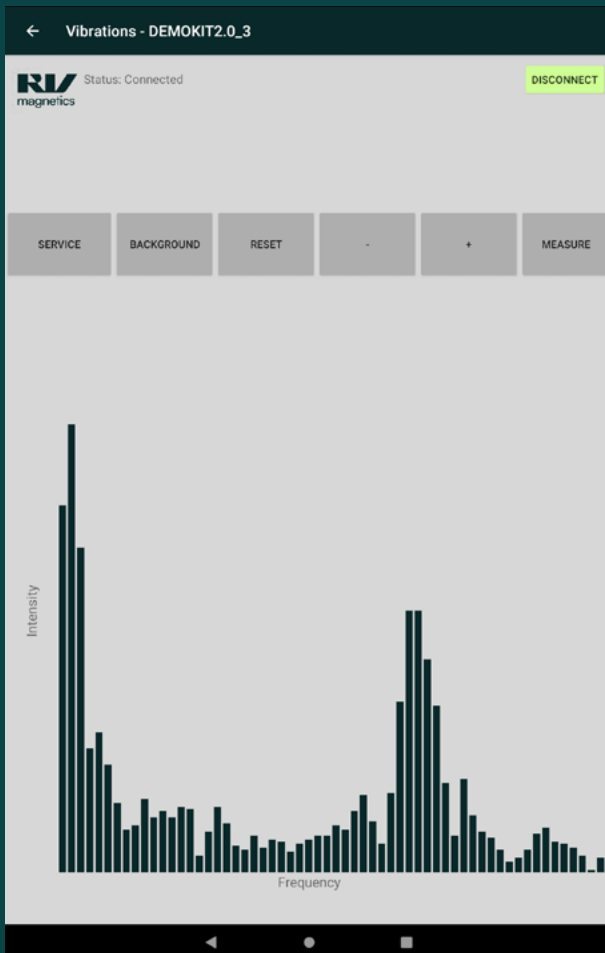

1. Step

- Insert the **4** carbon composite into one of the guides (“ears”). It has a small hole for precise placement.

2. Step

- Add the Vibration weight **5** on the free (inner) end of the composite strip.

3. Step

- Pluck the composite to create vibrations, which are detected by the MicroWire.

4. Step

- Vibrations are electronically analyzed to calculate the frequency spectra via the Fast Fourier Transform shown in the app.

Once the carbon strip (V1/V2/V3) has been inserted correctly, press the background button.

RAW measurement

Spare MicroWires (if included in the DemoKit) can be attached or embedded in non-magnetic materials by the users. Afterwards, it is possible to perform measurements with an external sensing coil **6**. The measurement must be performed under the specified conditions (as explained in the video manual).

1. Step

- After connecting the external coil to the main DemoKit body, it is possible to perform non-calibrated raw measurements on spare MicroWires or on all included bars.

2. Step

- To begin, attach or embed the MicroWire into the material of interest.

3. Step

- For accurate measurement, place the external coil close to the MicroWire, positioned parallel above it with one end aligned to the coil's long axis. Once in place, start the measurement and record data continuously.

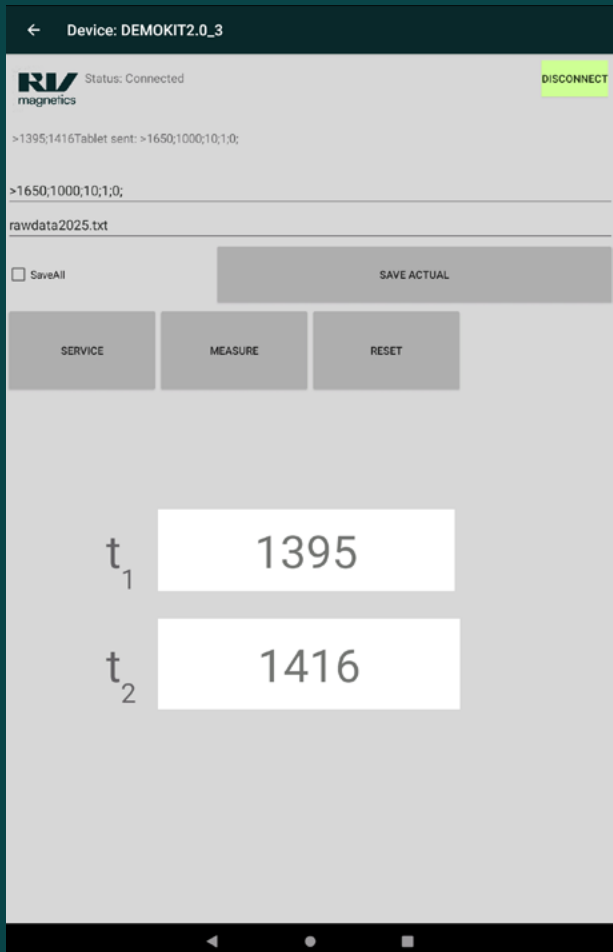

Recommendations & FAQ's

Recomendations

- In case of an application malfunction or other issues, it is advisable to turn the DemoKit and the application off, then turn both back on.
 - During measurement/use of the application, only the application being used must be running; all other applications must be closed.
-

FAQ

The device doesn't light up after turning on.

→ Check if the power bank is properly inserted and charged.

I inserted a strip but nothing happens.

→ Make sure it's correctly oriented (label facing up) and securely inserted.

Can I use a different power bank?

→ Yes, as long as it has the same output specs and USB connector.

Can I measure through objects?

→ Yes, it can detect signals through thin, non-metallic, non-magnetic obstacles.

Maintenance and Care

- Clean with a dry or slightly damp cloth. Do not use harsh cleaners.
- Store in the original case or a safe, dry environment.
- MicroWires and strips are fragile — handle with care, avoid excessive pressure or bending.



About RVmagnetics

Reliable & innovative partner in custom multi-sensing of physical quantities

RVmagnetics is renowned for developing the smallest passive sensor worldwide — the MicroWire. This groundbreaking technology is the foundation of the company's R&D focus, which centers on sensor miniaturization, prototyping, and tailored integration into clients' specific applications. Since its founding by physicist and academic Prof. Dr. Rastislav Varga, the company has grown organically, driven by the evolving needs of visionary partners seeking novel sensing capabilities.

RVmagnetics has since become a trusted collaborator for innovation leaders across diverse sectors, from industrial manufacturing to medical technology. The company is headquartered in Slovakia, European Union.

RVmagnetics was selected in 2025 for Phase 1 and 2 of the NATO Defence Innovation Accelerator for the North Atlantic (DIANA) Programme as one of 15 companies selected from more than 2,600 proposals. Since 2015, the company has continuously pushed the boundaries of innovation, earning more than a dozen national and international accolades.

Our journey has been recognised by top-tier organisations such as Deloitte, TechConnect, EIT Manufacturing, INAM, BIND 4.0, JEC Group and ADMA, and we have been proud participants in prestigious European and US innovation programmes.



Contact

Emails:

marhefka@rvmagnetics.com

hovhannisyan@rvmagnetics.com

Website:

www.rvmagnetics.com

